

SHERLOCK

LASTS LONGER

Instruction Manual

MANBBGC45 REV D 25/06/20

MODEL: BBGC45















SILVAN AUSTRALIA PTY. LTD.

ABN 48 099 851 144

FOR SERVICE SUPPORT PH 1300 745826
info@silvanaust.com

Parts Supplied

Part NO.	Part name	Part picture	Qty
1	Steel tray		1
2	Wheel		2
3	Bolt		5
4	Small Flat washer		5
5	Spring washer		5
6	Nut		4
7	Wing nut		1
8	Split pin		2
9	Large Flat Washer		2
10	A		1
11	B		1
12	C		1

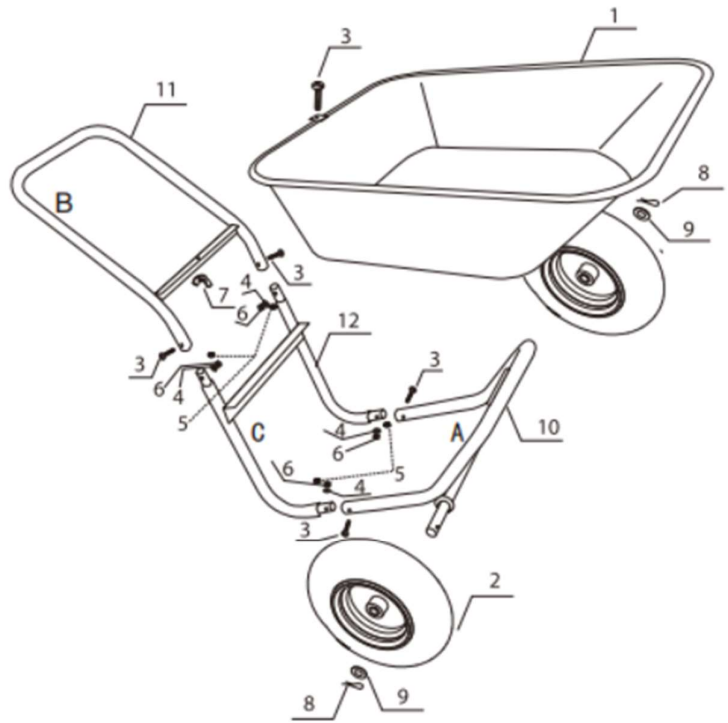

Installation

IMPORTANT: Do not allow children to use the cart without supervision, it is not a toy.

Step1. Find frame (A), then fit wheels to both sides using large flat washer and split pin.

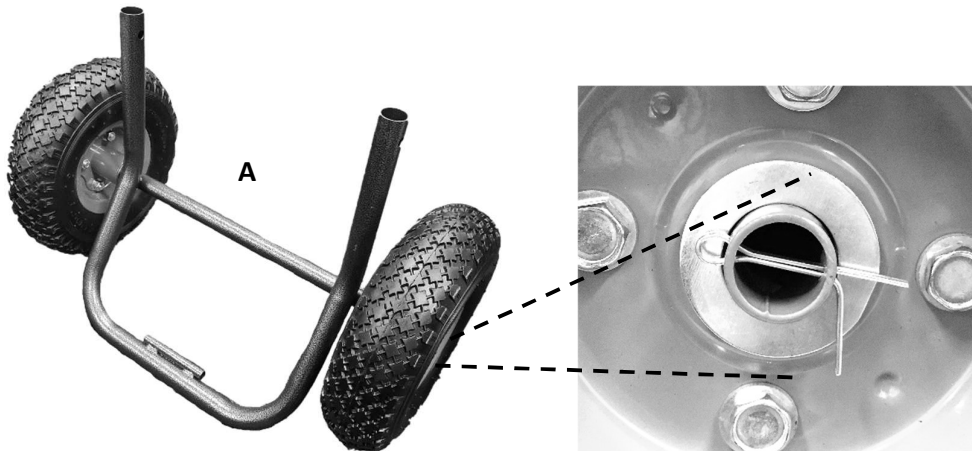

Installation

Step 2. Find frame (A), then fit (C) to assembled parts, fix both (A) (C) ends using bolts, small washers, spring washers and nuts.

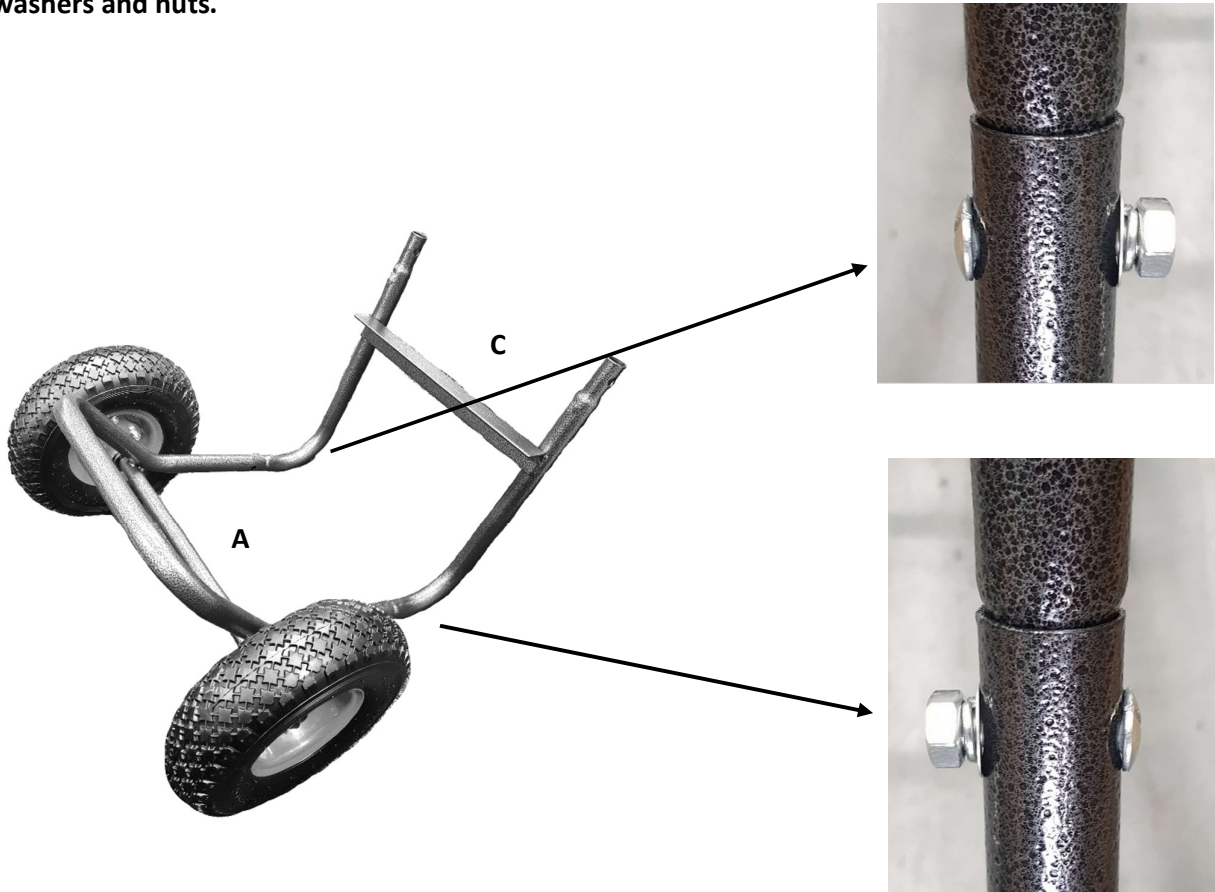

Step 3. Find frame (B), then fit to assembled parts with corresponding (C), fix both (C) (B) ends using bolts, small washers, spring washer and nuts.

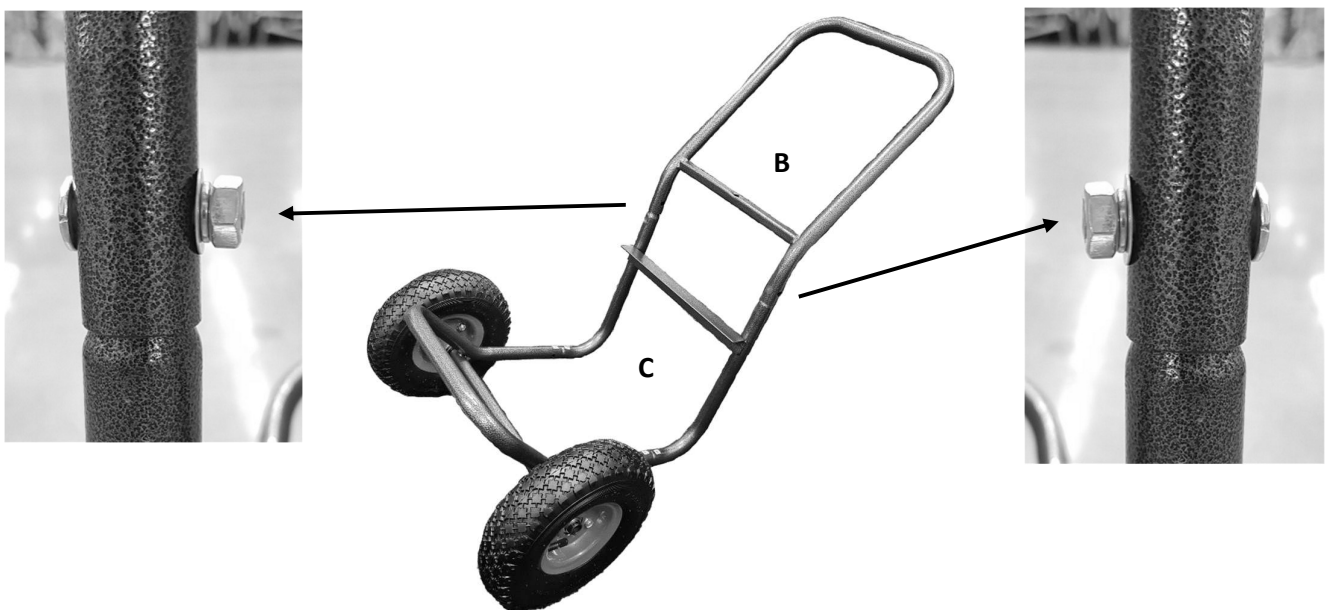

Installation

Step4. Slide steel tray into frame. Refer to photo below for tray direction.



Step5. Fix tray to frame using bolt and wing nut.

